



FLECK Light tile



PRODUCT INFORMATION

FLECK light tiles are made of unbreakable, very light and transparent PETG plastic and have high light transmitting. Depending on the type of roof tile, they are suitable for individual and extensive laying and are available in a wide range.

Also available as alternative:

Corrugated profile 5 ~ 480 × 900 mm (small format)

Material

Made of extremely unbreakable PETG plastic with high light transmitting of more than 90 %.

Construction material (fire reaction) class

B1 as per DIN 4102

Melting temperature

< 200°C*

Accessories

Securing strap for storm-proof mounting

Note

- The light tile is fastened to the roof battens with the enclosed screw nails in the head area
- The securing strap at the back prevents the light tile from lifting and rattling

* Can be used in conjunction with fire protection concepts for smoke extraction areas

TECHNICAL NOTES

Installation note

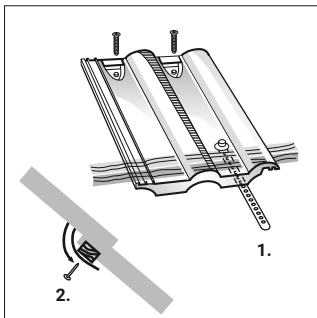

1. Screw the light tile to the roof batten, tauten the securing strap
2. Fasten the securing strap to the lower roof batten with a nail

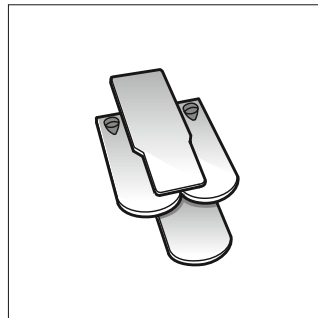

Beaver round segment cut 18/38 multi-tile

Beaver roof tile variants

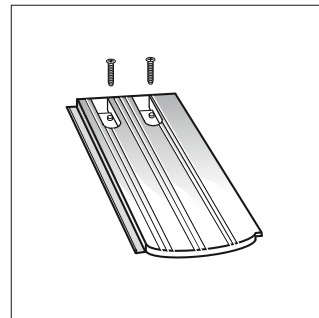

Beaver segment cut 18/38 individual

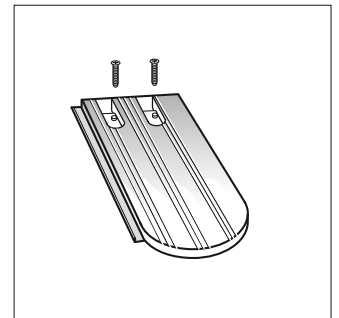

Beaver round cut 18/38 individual